



indef

TECHNOLOGY NETWORK TRUST



Visit Our Website
indef.com

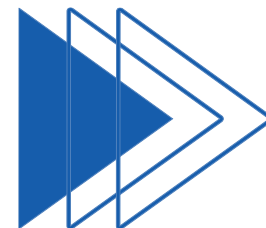

About Us



- We are a **Bajaj Group** company
- Formed in **1962** in collaboration with **Heinrich De Fries GmbH, Düsseldorf, Germany**
- Integrated design and manufacturing facilities at **Khalapur** and **Chakan, India**
- Quality systems certified to **ISO 9001:2015**
- Mechanical hoists **ISI & CE** certified
- We are the **market leader** for hoisting solutions in India
- Team size: 165+

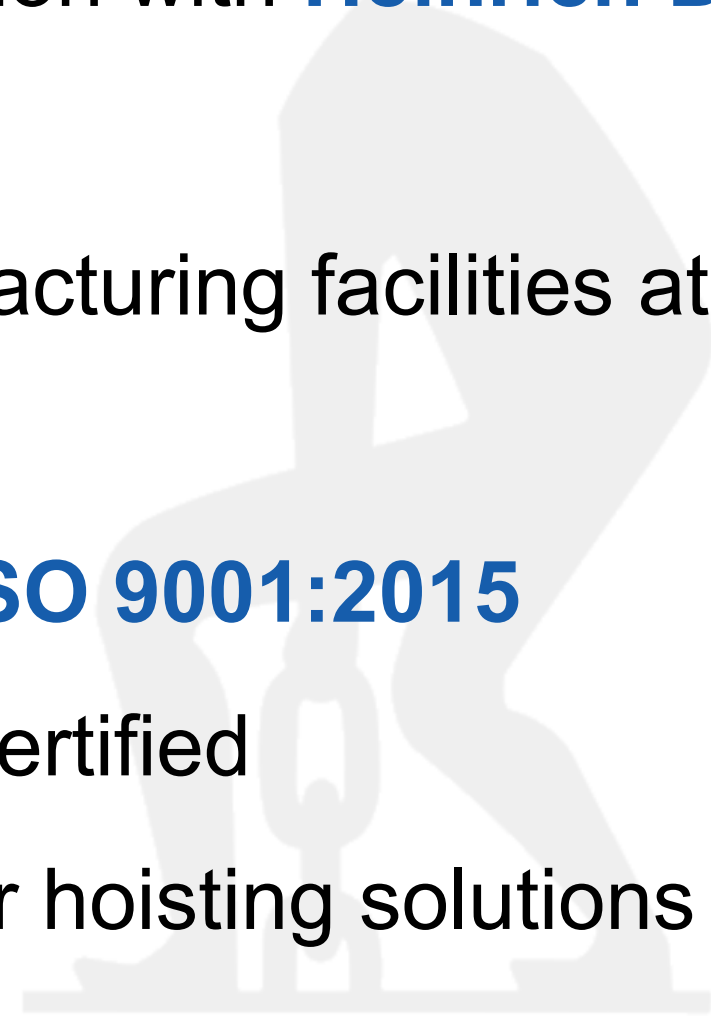

Management Team

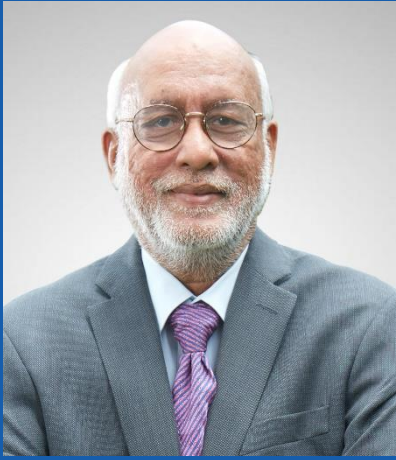

Shri. Shekhar Bajaj
Chairman



Mr. Amit Bhalla
President & CEO



Mr. Vivek Mahendru
EVP Operations



Mr. Vijay P Singh
CFO



Mr. Debi Prasad Padhy
Sr. GM- Sales & Mktg.

Timeline



indef

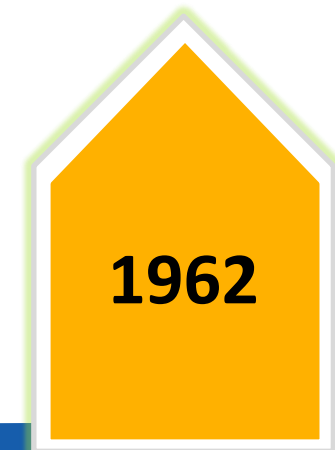

1962

HHL was incorporated



Got Listed on Bombay Stock Exchange



1964

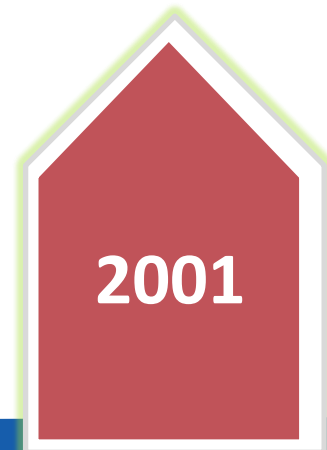

2001

Got Listed on National Stock Exchange



Achieved the **100 Crore** Turnover Mark



2008

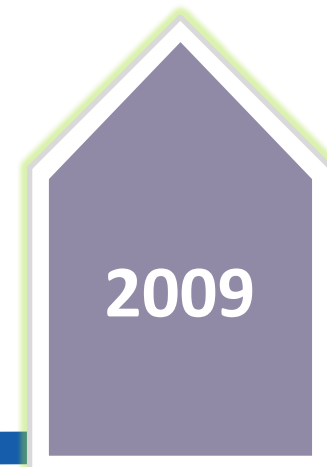

2009

Our current Manufacturing Facility at **Khalapur** became Operational



Celebrated Our 50 years Anniversary



2012



2014

New Crane manufacturing facility started at **Chakan, Pune**



2022

Shifted to a **3x larger factory** at **Chakan, Pune**



Driven by a *customer centric* approach,
BAJAJ INDEF aims to be the one stop
solution provider for all in-plant unitised
material handling and storage solutions!



Technology Leadership

- Our market leadership is driven by our continuous innovation capabilities enabling us to provide contemporary, robust solutions
- We use cutting edge technology tools like **SolidWorks** with **FEA, Cadec** for our designing
- Our capabilities are enhanced by our tie up with eminent partners
 - **Planeta Hebetchnik GmbH, Germany**
 - **VHT, Italy**

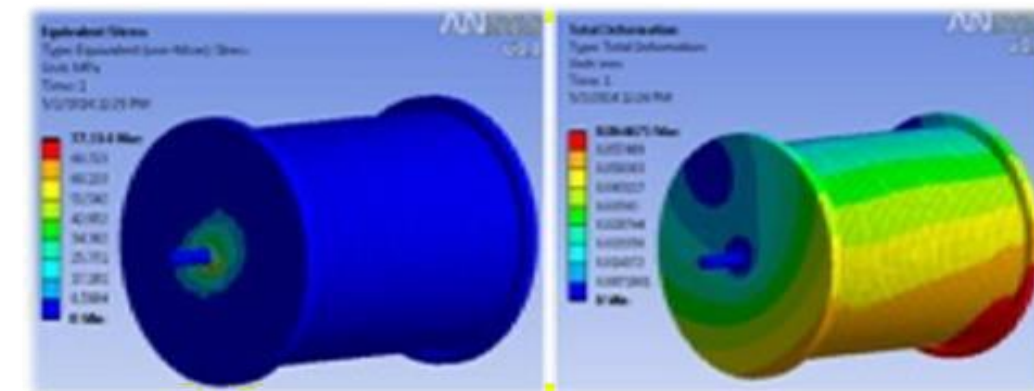
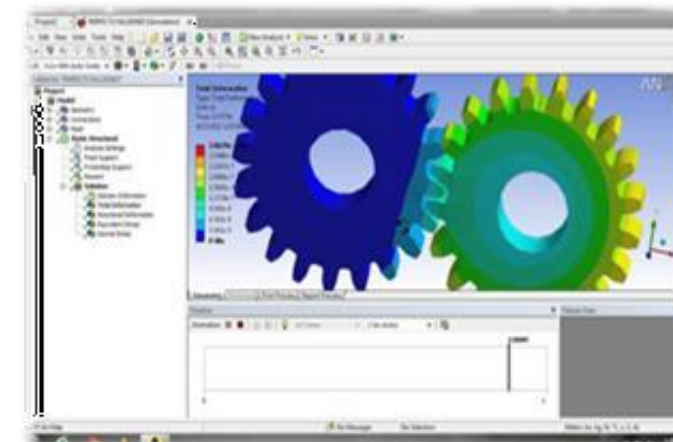
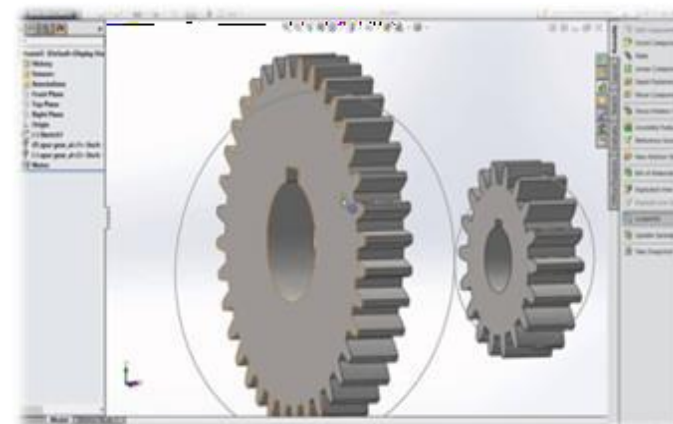
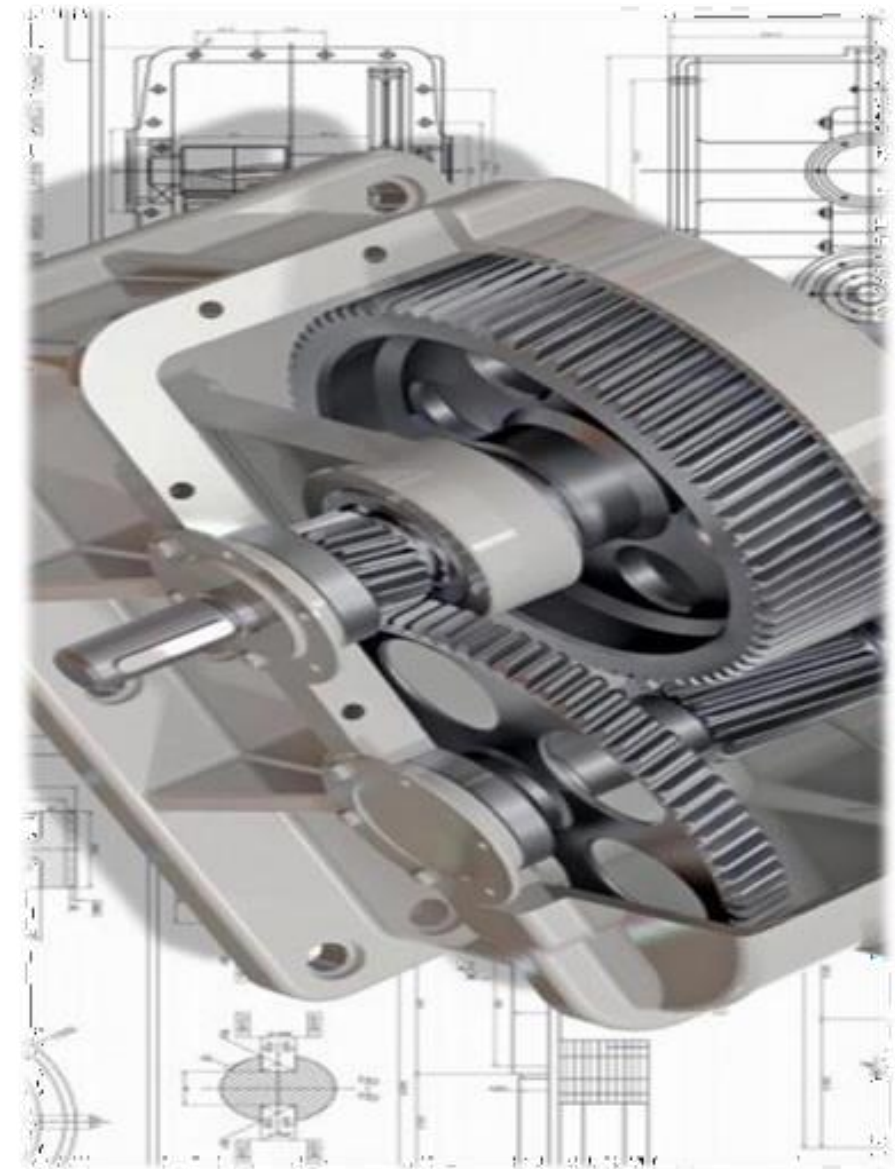

Pan-India Network



➤ Direct Sales Network

➤ Regional Offices

- Delhi
- Kolkata
- Chennai

➤ Dealer Network

- 40+ Authorised Business Partners (Stock and Sell distributors) countrywide
- Supported by over 100 Authorized Retailers
- 40+ INDEF Clinics for better customer service

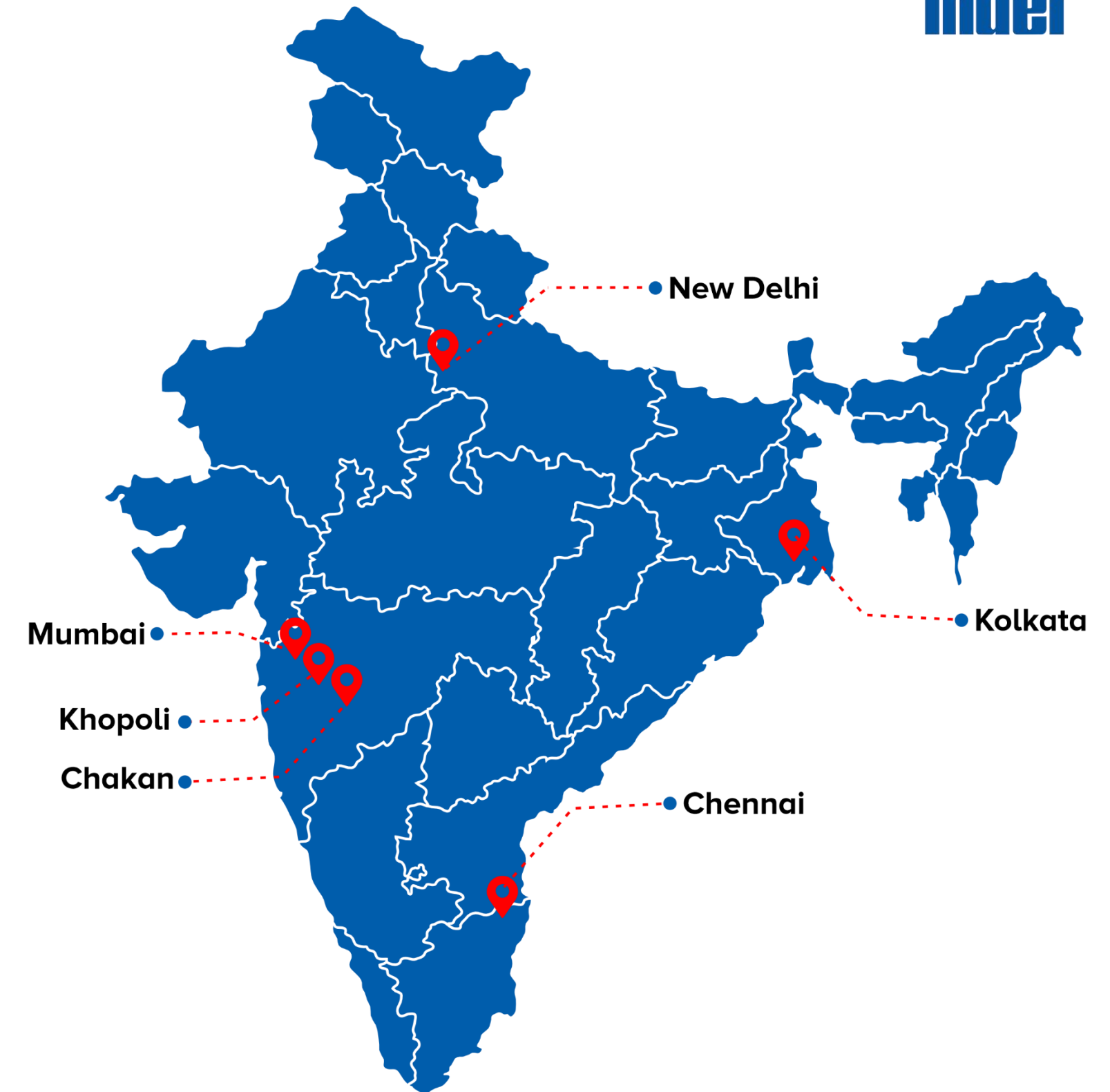

Our Manufacturing Facilities



Hoist Manufacturing Unit, Khalapur

Crane Manufacturing Unit, Chakan

Products & Solution Range

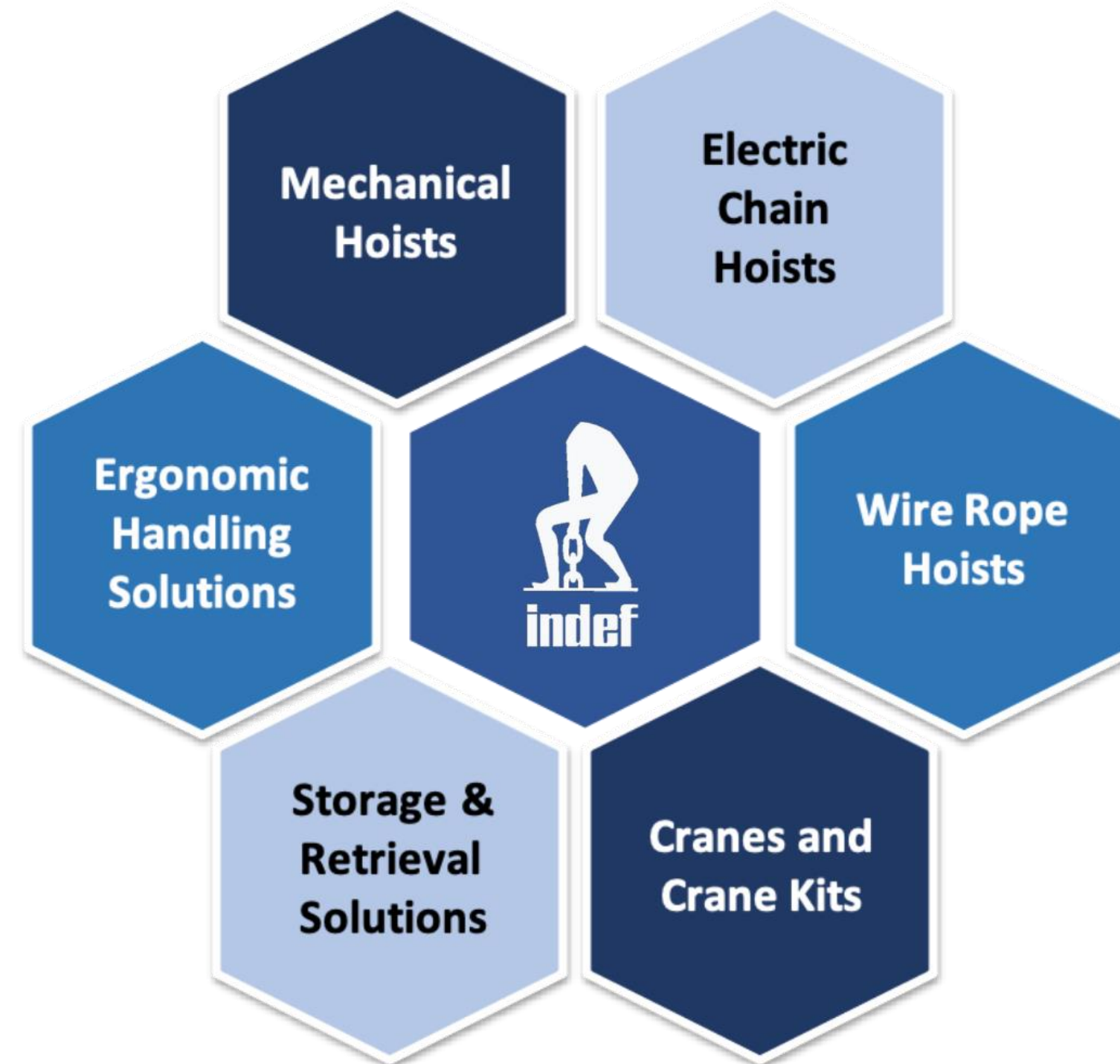

Mechanical Hoists



➤ Product Lines

- Chain Pulley Blocks (CPB)
 - Ratchet Lever Hoists (RLH)
 - Pulling & Lifting Machines (PLM)
-
- Available in 5 models / series
 - **Indef P** - Heavy Duty CPB with German technology.
 - **Indef M** - Medium Duty CPB with British technology.
 - **Indef Stier** - Medium Duty CPB & RLH with German technology.
 - **Indef C** - Medium Duty CPB with Indigenous Compact Design
 - **Indef R** - India's Best 360 Degree Chain Pulley Block

- Capacity Range: 0.5 T to 40 T
- CE and ISI Certified
- Specials:
 - **Spark proof** models with **ATEX certification**
 - Low headroom models
 - Safety features like load limiter / slipping clutch*

INDEF-C

<https://youtu.be/v1vfclx-fAQ>



Electric Chain Hoists



- Range from **0.25 T to 30 T**
- Lift height up to **100 meters**
- Single Speed / Dual Speed / VFD Control
- Available in following series:

EH II / HC + / CH – III & CH – IV

- Robust design
- Proven European technology*
- CE and ATEX certified
- Available in Flame Proof variants



Wire Rope Hoists

BAJAJ

indef

- Range from **1T to 90T**
- Available in following series
 - **iR / UR / W R H I - II - III / HW / SMD**
- Proven European Technology
- Lift height up to **125 meters**
- Single Speed / Dual Speed / VFD Control
- Optionally available with **VLVS™** technology
- Standard short headroom trolley hoist
- Available in Flame Proof variants
- CE and ATEX certified



iCRANE EOT Cranes



- For standard cranes from **1T to 70T**
- Available with **iR / UR / SMD** wire rope hoists
- End carriages and crabs with German technology
- **EN9 material** double flanged wheel blocks with matching travel geared motors
- Optimized structure for **low deadweight & agility**
- Cable-less power supply with Indef conductor system
- **iQUE™** (intelligent eQ uipment U sagE)
- Tracker available optionally

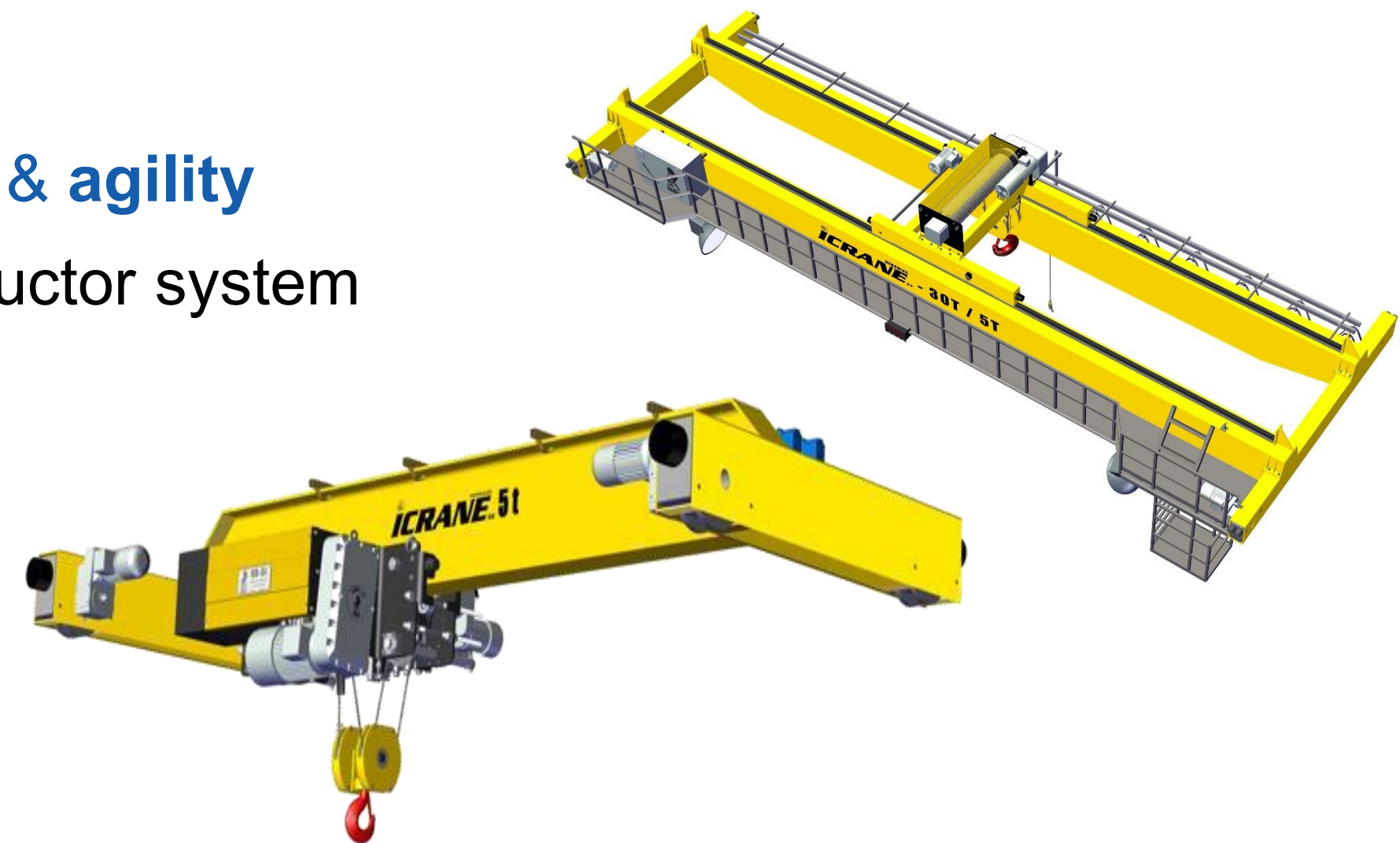
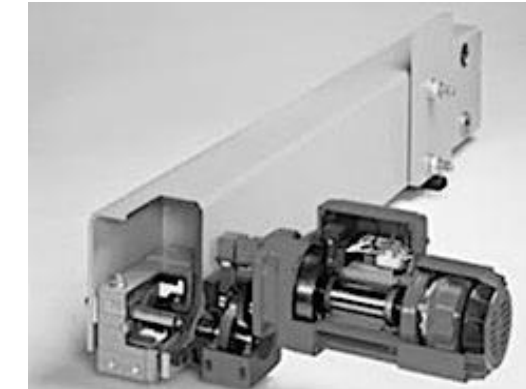

iCrane LR+ Light Crane Systems



- Higher Productivity for **SWL up to 2T**
- Compatible with Manual and Electric trolleys
- **External trolleys** for enhanced safety
- Easy to inspect & maintain
- Best joint system with **auto locking** feature
- Reduced horizontal stress on structure (**Ball and Socket Joint**)
- Can be configured in monorail, single girder crane and jib crane
- **High AMOI** gives strength to the complete system

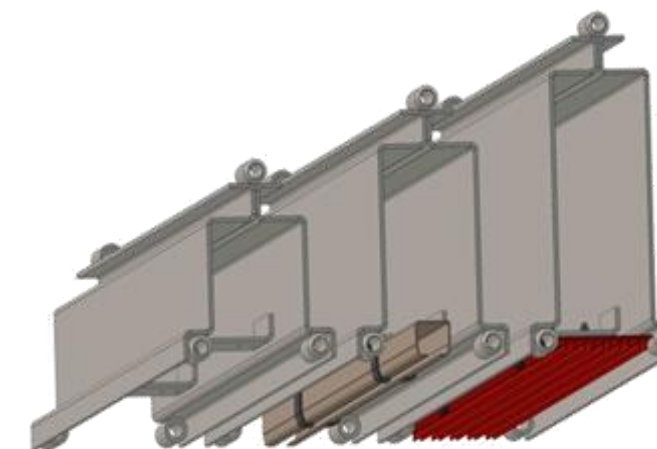
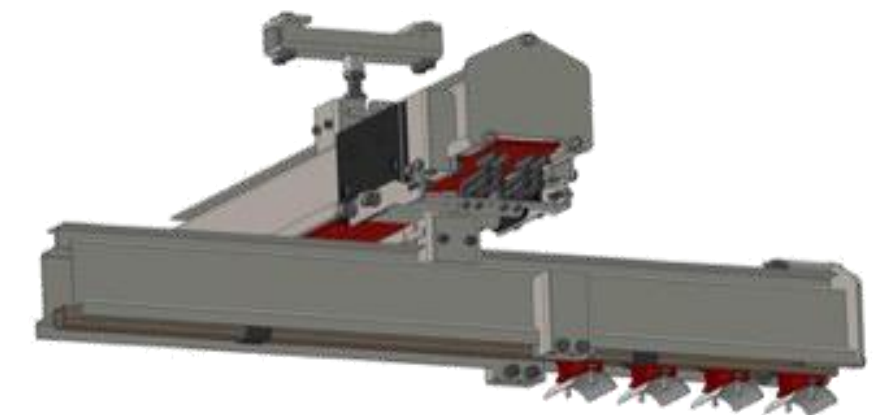
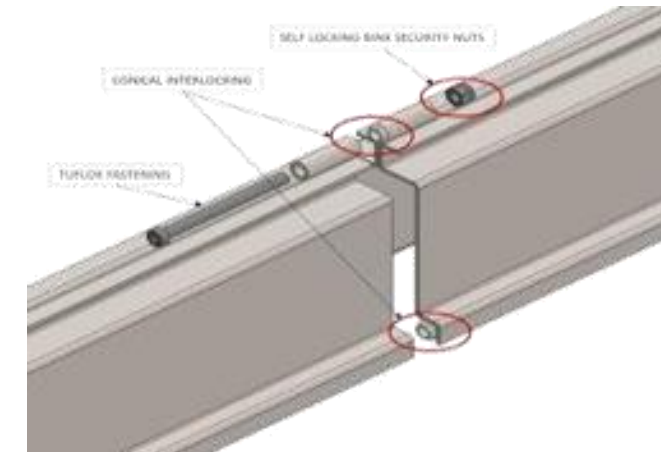

iStacker - Floor Operated Stackers



indef

- Affordable, entry-level storage & retrieval solution
- Racks **up to 8 m** supported, including in narrow aisles
- Suitable for **double-deep** and **multi-aisle** storage.
- Provided with a **360° turntable** for rotation.
- Material Storage & Retrieval without degradation of load capacity
- Intelligent user-friendly interface to optimize operations



Roll- out Racks

- Compact storage equipment ideal for long bars, channels, flats, pipes & tubes
- Stores material vertically up to **5 levels**
- All item in **ROR**, can be accessed independently in **FIFO** manner
- Increases productivity by reducing manual hassle of arranging products each time you retrieve some material

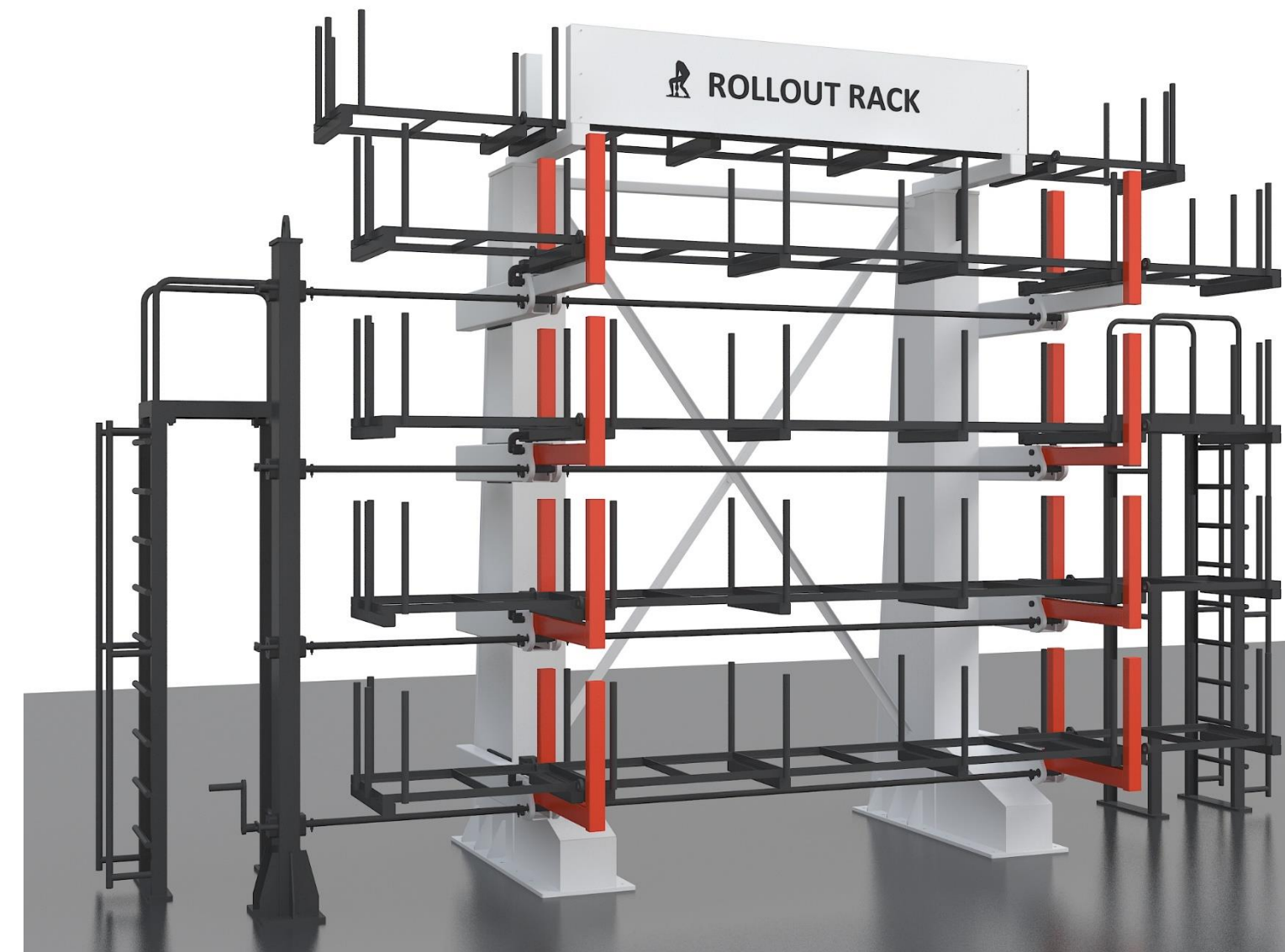

Indef Powered Crane Kit



➤ Standard Offering:

- Next generation iR series wire rope hoist of 2T, 3.2T, 5T & 10T capacity
- Box end carriages
- Electro-Mechanical overload instrument
- Variable speed for Hoist, Trolley & Bridge
- Flat cable festooning running on galvanized C-track
- Separate track for moving pendant through flat cable with plug socket
- High tensile girder end carriage joint bolts, joint plates, derailment guard, buffers, sweeper plate
- 6 Way pendant with emergency

Build Cranes Quick & Convenient...

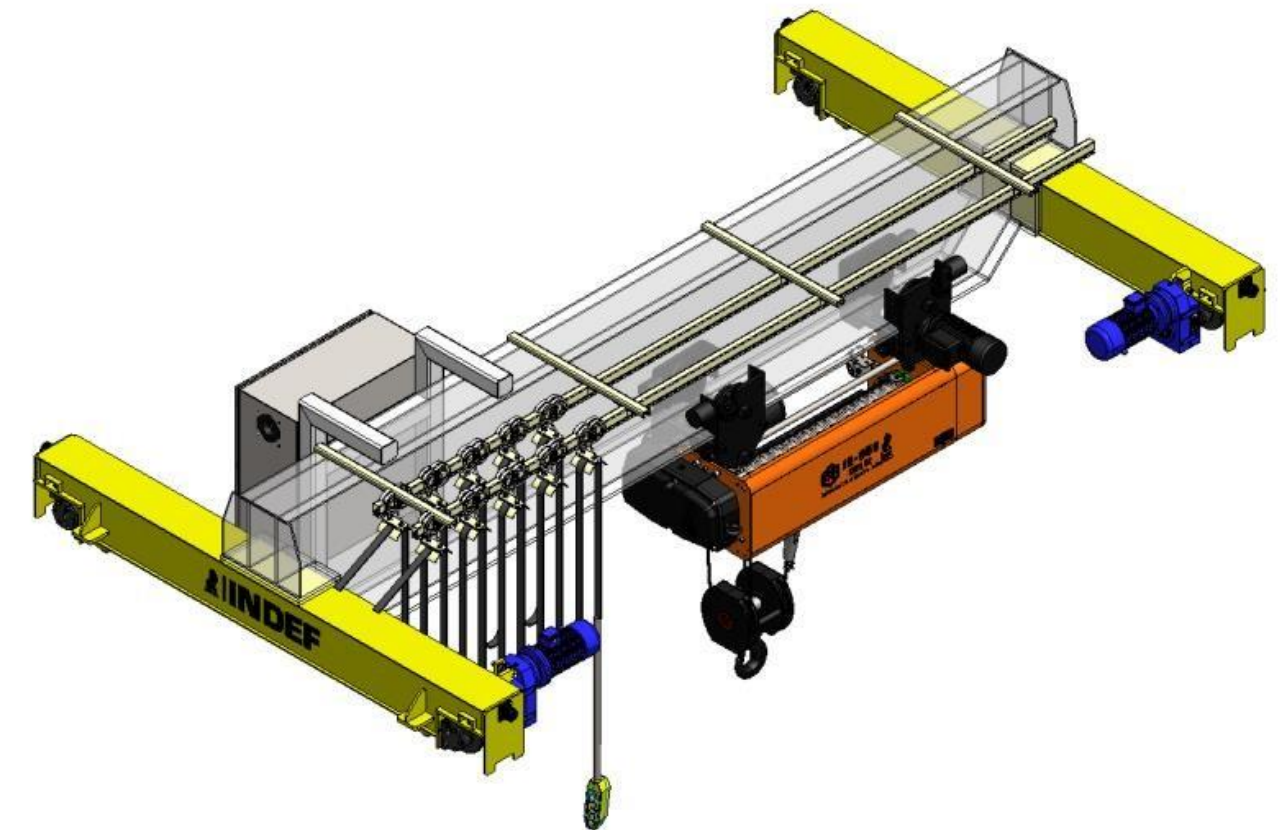

<https://youtu.be/vopek9U50I>

Global Presence



Effective from January 2022, KG International is appointed as our exclusive Authorized Business Partner for a large list of countries covering the Middle East and Africa region.

- Established in 1968, KG International FZCO is a leading bearing company with ISO 9001:2015 certification. KG International is preferred for its quality products, services, and efficient supply chain. Today, KG International has a presence spanning five continents in 50+ countries. They are also associated with IATF 16949:2016 certified manufacturing factories in Asia, with proven stringent quality controls to meet the specific needs of our global customers.



Effective from July 2022, Delcot Group has been appointed as our exclusive Authorized Business Partner for the country- Bangladesh

- Delcot Group and its sister concerns are limited companies that have been involved in various business enterprises since 1976. Their products include specialized lubricants, Belts and bearings for a large range of machines, wax rolls for winding machines in spinning mill etc. They also have retail outlets in Dhaka and Chittagong city for the distribution of their product range. They are constantly adding new products to bring additional benefits to clients.



With effect from 2022, BATAS Organization has been assigned as HHL's exclusive Authorized Business Partner for Nepal.

- The BATAS is a business house, established in 1967 A.D., which offers a diverse portfolio in hospitality, hydropower, hospitals, financing, trading, and manufacturing. They have 19 subsidiary companies with a network spanning throughout Nepal.

Solution For Every Industry



Our products are suitable for all the industries in catering to their material handling requirements:

- Automotive and Auto-components
- Engineering
- Metals and Metal Processing
- Oil, Gas and Petro-chemicals
- Cement and Infrastructure
- Food processing
- Chemicals, Fertilizers and Pharmaceuticals
- Power Generation (Hydro / Thermal / Nuclear)

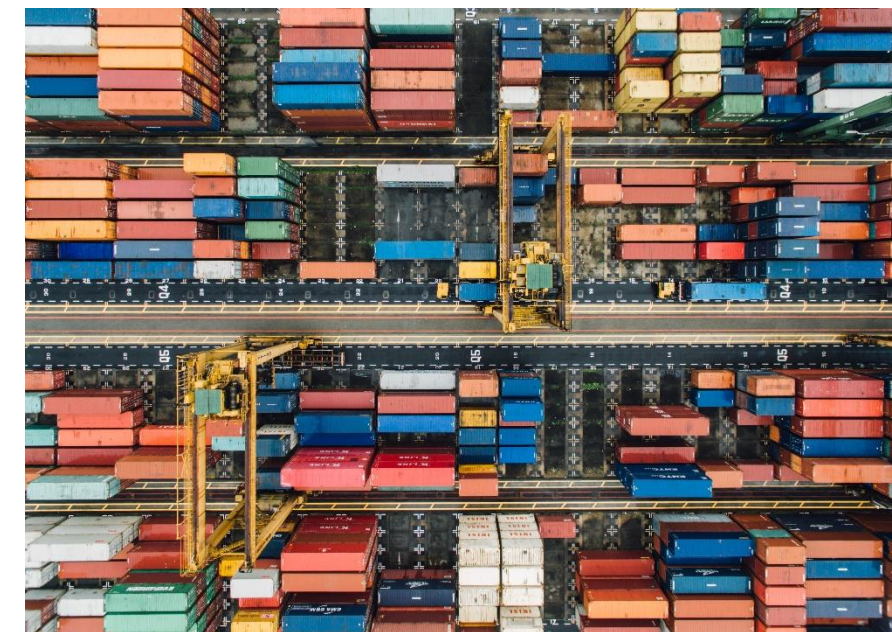
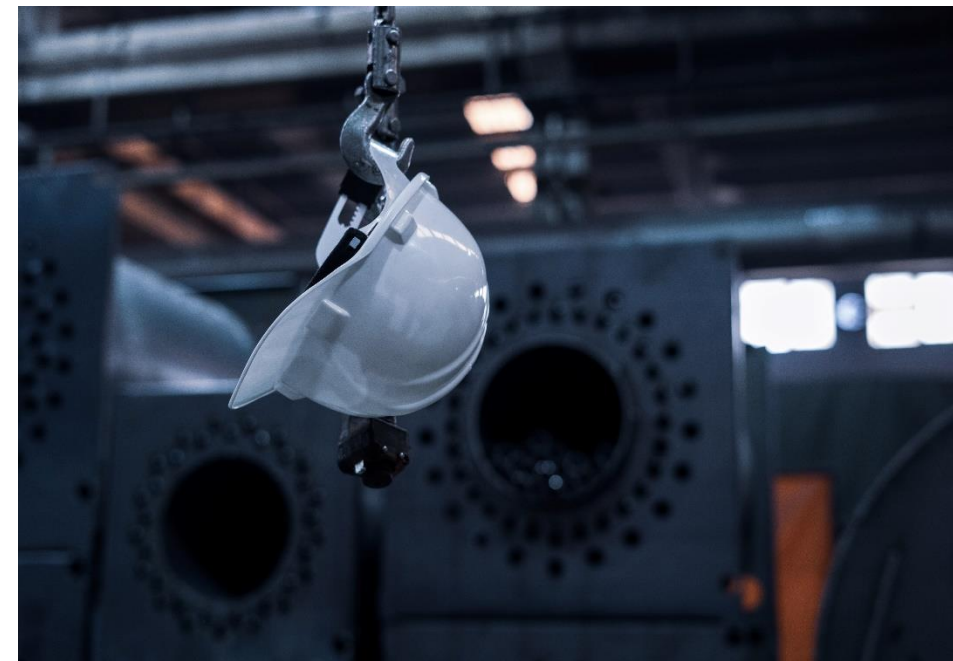

Why choose us?

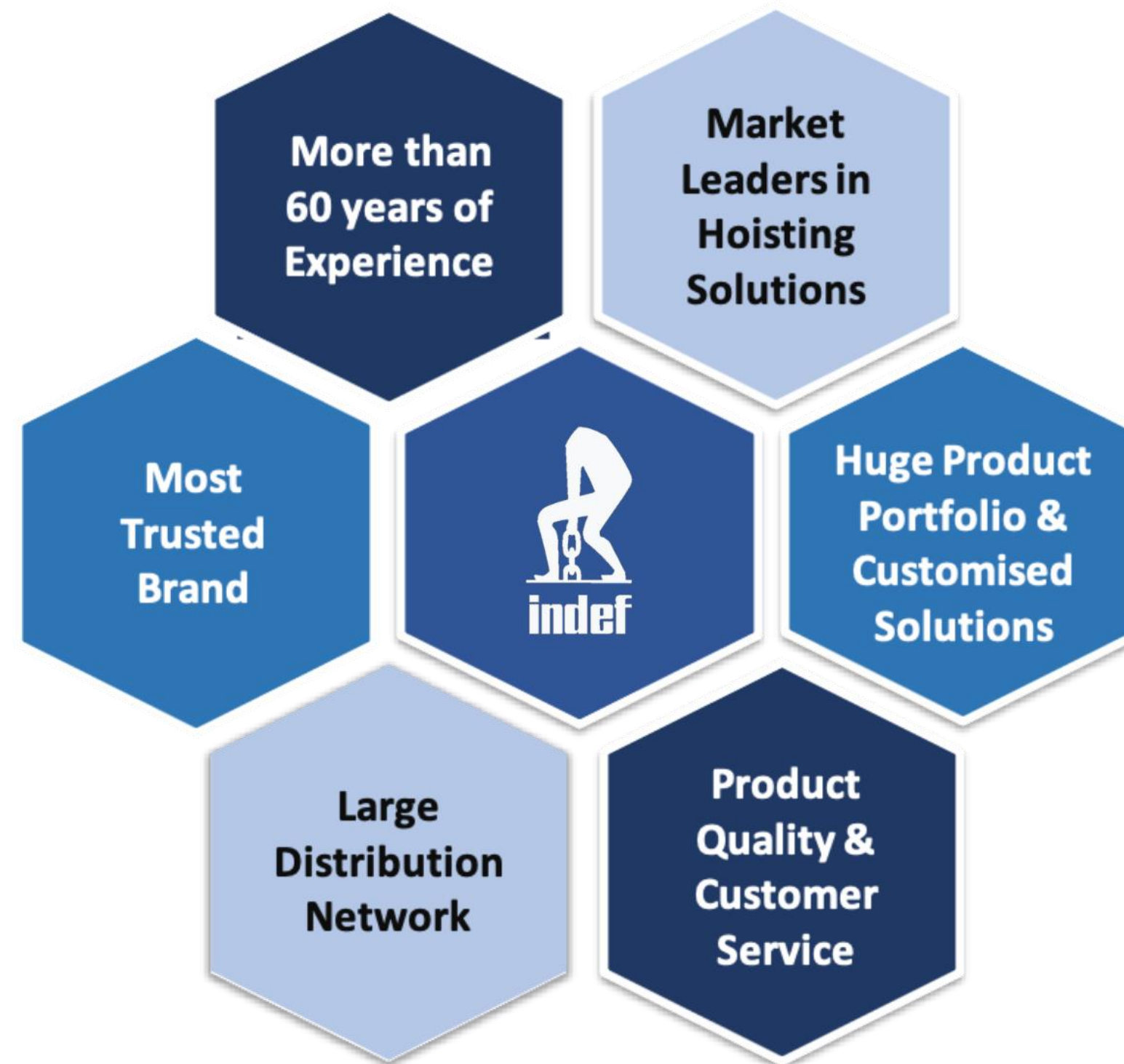

Our Clientele



indef



Awards & Recognitions



indef





BAJAJ INDEF,
501-504, Shelton Cubix,
15/87 CBD Belapur,
Navi Mumbai, MH
400014, INDIA



+91 (22) 489-33303



enquire@indef.com



www.indef.com

DETAILS OF FAMILIARIZATION PROGRAMMES IMPARTED TO INDEPENDENT DIRECTORS
(Under Regulation No. 46 (2) (i) of SEBI (Listing Obligations & Disclosure Requirements) Regulation 2015)

FY 2015-16-

- 1) A brief about the Company and Khalapur Factory Visit dated 6-2-2016
- 2) To aware Role, Rights, Functions and Responsibilities of Independent Directors as per Companies Act 2013 dated 6-2-2016

Name of the Independent Director	No. of familiarization programme	No. of Familiarization programme attended by Independent Directors	Number of hours spent by independent directors in such programmes
Shri Vinaya Mehrotra	2	2	One and Half Hours
Shri Mukul Updhyaya	2	2	One and Half Hours
Shri Gaurav Nevatia	2	2	One and Half Hours
Smt Shruti Jatia	2	2	One and Half Hours
Shri Vandan Shah	2	2	One and Half Hours
Shri Tushar Shah	2	2	One and Half Hours

FY 2016-17: A product details of the Company and Khalapur Factory Visit dated 10-02-2017

Name of the Independent Director	No. of familiarization programme	No. of Familiarization programme attended by Independent Directors	Number of hours spent by independent directors in such programmes
Shri Vinaya Mehrotra	2	-	One Hour & Fifteen Minutes
Shri Mukul Updhyaya	2	2	One Hour & Fifteen Minutes
Shri Gaurav Nevatia	2	2	One Hour & Fifteen Minutes
Smt Shruti Jatia	2	2	One Hour & Fifteen Minutes
Shri Vandan Shah	2	2	One Hour & Fifteen Minutes

FY 2017-18: Product upgradation details of the Company and Khalapur Factory Visit dated 14-02-2018

Name of the Independent Director	No. of familiarization programme	No. of Familiarization programme attended by Independent Directors	Number of hours spent by independent directors in such programmes
Shri Vinaya Mehrotra	2	2	Forty Five Minutes
Shri Mukul Updhyaya	2	2	Forty Five Minutes
Shri Gaurav Nevatia	2	2	Forty Five Minutes
Smt Shruti Jatia	2	-	Forty Five Minutes
Shri Vandan Shah	2	2	Forty Five Minutes

Corporate Office

501-504, Shelton Cubix
Sector 15, Plot # 87
CBD Belapur
Navi Mumbai 400614,
India

Plant/Factory

• Khalapur
• Chakan
Regional Offices
Pune, Delhi, Chennai,
Kolkata

Contact

T: +91 22 45417301
F: +91 2192 274125
E: indef@indef.com
U: www.indef.com

Registered Office

Bajaj Bhawan, 2nd Floor
226, Jamnalal Bajaj Marg
Mumbai 400 021, INDIA
CIN:
L45400MH1962PLC012385

FY 2018-19: Product upgradation details of the Company dated 08-02-2019

Name of the Independent Director	No. of familiarization programme	No. of Familiarization programme attended by Independent Directors	Number of hours spent by independent directors in such programmes
Shri Vinaya Mehrotra	2	2	One hour
Shri Mukul Updhyaya	2	2	One hour
Shri Gaurav Nevatia	2	2	One hour
Smt Shruti Jatia	2	-	One hour
Shri Vandan Shah	2	2	One hour

FY 2019-20: Product upgradation details of the Company & factory visit dated 11-02-2020

Name of the Independent Director	No. of familiarization programme	No. of Familiarization programme attended by Independent Directors	Number of hours spent by independent directors in such programmes
Shri Gaurav Nevatia	2	2	Forty Five Minutes
Smt Shruti Jatia	2	2	Forty Five Minutes
Shri Vandan Shah	2	2	Forty Five Minutes

FY 2020-21: Product upgradation details of the Company dated 08-02-2021

Name of the Independent Director	No. of familiarization programme	No. of Familiarization programme attended by Independent Directors	Number of hours spent by independent directors in such programmes
Shri Gaurav Nevatia	1	1	Thirty Minutes
Smt Shruti Jatia	1	1	Thirty Minutes
Shri Vandan Shah	1	1	Thirty Minutes

FY 2021-22: Market, strategy updates dated 09-02-2022

Name of the Independent Director	No. of familiarization programme	No. of Familiarization programme attended by Independent Directors	Number of hours spent by independent directors in such programmes
Shri Gaurav Nevatia	1	1	Thirty Minutes
Smt Shruti Jatia	1	1	Thirty Minutes
Shri Vandan Shah	1	1	Thirty Minutes

Corporate Office

501-504, Shelton Cubix
Sector 15, Plot # 87
CBD Belapur
Navi Mumbai 400614,
India

Plant/Factory

• Khalapur
• Chakan
Regional Offices
Pune, Delhi, Chennai,
Kolkata

Contact

T: +91 22 45417301
F: +91 2192 274125
E: indef@indef.com
U: www.indef.com

Registered Office

Bajaj Bhawan, 2nd Floor
226, Jamnalal Bajaj Marg
Mumbai 400 021, INDIA
CIN:
L45400MH1962PLC012385



indef

FY 2022-23: Product upgradation details of the Company , strategy & market updates and factory visit dated 09-02-2023

Name of the Independent Director	No. of familiarization programme	No. of Familiarization programme attended by Independent Directors	Number of hours spent by independent directors in such programmes
Shri Gaurav Nevatia	1	1	One hour
Smt Shruti Jatia	1	-	-
Shri Vandan Shah	1	1	One hour

Corporate Office

501-504, Shelton Cubix
Sector 15, Plot # 87
CBD Belapur
Navi Mumbai 400614,
India

Plant/Factory

• Khalapur
• Chakan
Regional Offices
Pune, Delhi, Chennai,
Kolkata

Contact

T: +91 22 45417301
F: +91 2192 274125
E: indef@indef.com
U: www.indef.com

Registered Office

Bajaj Bhawan, 2nd Floor
226, Jamnalal Bajaj Marg
Mumbai 400 021, INDIA
CIN:
L45400MH1962PLC012385



**Corporate Office**

501-504, Shelton Cubix
Sector 15, Plot # 87
CBD Belapur
Navi Mumbai 400614,
India

Plant/Factory

- Khalapur
- Chakan

Regional Offices

Pune, Delhi, Chennai,
Kolkata

Contact

T: +91 22 45417301
F: +91 2192 274125
E: indef@indef.com
U: www.indef.com

Registered Office

Bajaj Bhawan, 2nd Floor
226, Jarnalal Bajaj Marg
Mumbai 400 021, INDIA
CIN:
L45400MH1962PLC012385

